

GA7518D

Cargo Plane

Don't forget to check out...



Crafty Kate!

A FREE resource with craft tips, themes, videos and more @ssww.com!

Get Social—Share your craft tips or fun craft experience by visiting Crafty Kate @ www.ssww.com/crafty-kate/!

MAKING IT EASY to SAVE MORE on your next order!

\$10 OFF

Your Next Order of only \$39⁰⁰ or more.

Please mention Offer Code: **M2467**

Minimum order \$39 excludes shipping and taxes.

Limit one per order.

May not be combined with other offers or bid or contract pricing.

See current S&S® catalog or Help at ssww.com for Offer Terms and Conditions.

We reserve the right to terminate this offer at any time without notice.

Call Toll-Free
1-800-243-9232

Online:
SSWW.COM

Email:
cservice@ssww.com

FAX:
1-800-566-6678

S&S Worldwide

© Copyright 2015 S&S® Worldwide Inc. All rights reserved.
No part of this project may be copied or duplicated without the express written permission of S&S Worldwide.

Kit may contain silicone gel packets, which should be removed before use.

Reorder Number

GA7518D

1.0

S&S Worldwide

MAKING IT EASY
to Help People Play and Learn

Cargo Plane

PLEASE READ ALL INSTRUCTIONS BEFORE STARTING

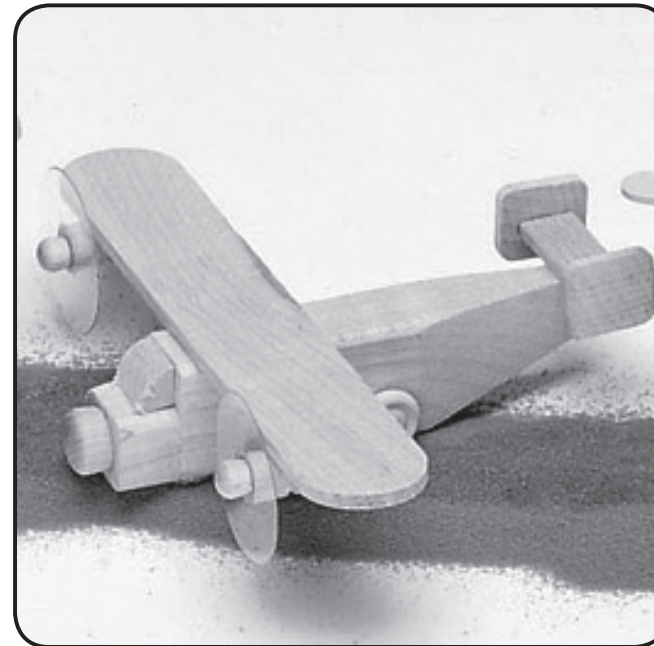

YOUR KIT CONTAINS:

- Wood Pieces
- Wood Dowels
- 2 Acetate Circles

YOU WILL NEED:

- Wood Glue
- Sandpaper (Optional)
- Acrylic Craft Paint (Optional)
- Stain (Optional)
- Flat Work Surface

PREP TIME: 10 minutes

PROJECT TIME: 30 minutes

INSTRUCTIONS:

1. Glue the cabin to the front of the fuselage, flush with bottom. (See Figure A).
2. Glue the windshield to the top of the cabin and flush to the front of fuselage. (See Figure B).
3. Glue nose centered onto the front of the cabin. (See Figure C).
4. Glue wheels to the sides of the fuselage, 1/2" back from the front edge of the fuselage and extending 1/8" below the bottom of fuselage. (See Figure D).
5. Glue stabilizer, centered on top of fuselage and flush to rear of fuselage. (See Figure E).
6. Center and glue fins on each end of stabilizer. (See Figure F).
7. Glue wing 1/2" back from front of fuselage and centered left to right. (See Figure G).
8. Glue wing engines to wing bottom, 1/2" from the side of the fuselage and extending 1/4" beyond the front edge of wing. Keep the tapered end facing towards the back. Be sure there is room for propellers. Glue propellers (acetate circles) centered on the front of each wing engine. Glue spinners to the center of each propeller. (See Figure H).

GENERAL WOOD INSTRUCTIONS:**SANDING**

The rule of sanding is "Never across the grain."

1. Do not tear sandpaper. If you do, the ragged edges will often scratch the wood surface.
2. For flat surfaces, wrap a piece of sandpaper around a block of wood or use a store bought holder. Start with a coarse grade of paper and finish with a fine grade paper (not included).
3. Be consistent. Do not sand one area with fine paper and another with coarse grade paper.

STAINING

1. Be sure the wood surface is smooth and clean. Stains can accentuate any roughness or scratches of cross grain sanding. Wipe off any dirt or dust with a soft cloth.
2. A base coat of sealer/primer and a light sanding before applying stain will ensure a uniform stain.
3. Apply stains in one direction following the wood grain. Use a soft brush or foam brush. Let the stain penetrate the wood, then wipe off excess stain with a soft cloth.
4. If stain looks too dark, dampen the cloth with water/thinner and wipe until you achieve the desired color. If stain is too light, let dry, then apply another coat of stain and wipe off.

FINISHES

1. Outdoor projects may be finished with polyurethane or varnish. **These are toxic and must be used in a well ventilated area.** Indoor projects may be finished with decoupage or left unfinished.

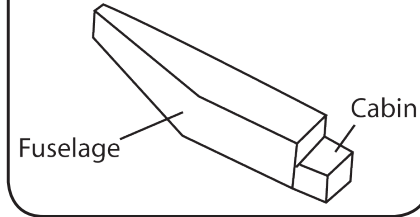
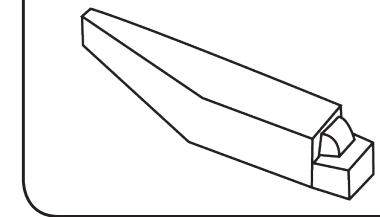
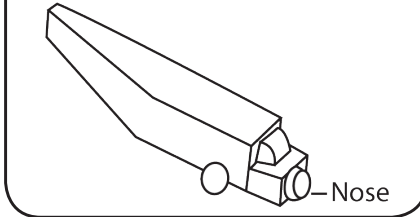
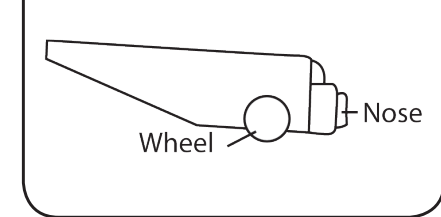
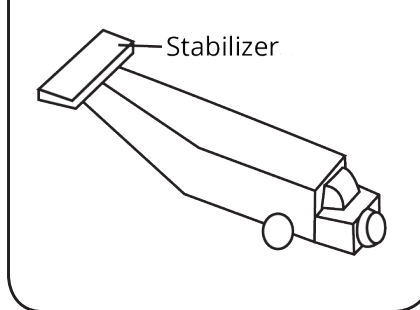
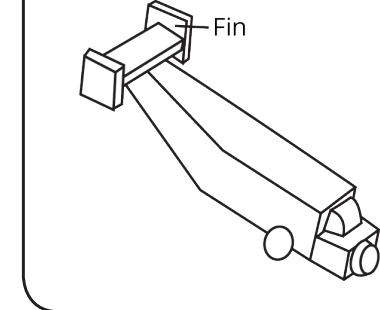
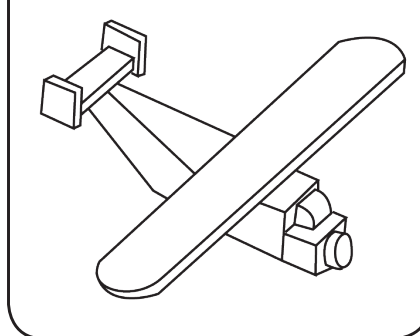
FIG. A**FIG. B****FIG. C****FIG. D****FIG. E****FIG. F****FIG. G****FIG. H**