

GA7519C

## Classic Cars - Model A

### GENERAL WOOD INSTRUCTIONS:

#### SANDING

The rule of sanding is "Never across the grain."

1. Do not tear sandpaper. If you do, the ragged edges will often scratch the wood surface.
2. For flat surfaces, wrap a piece of sandpaper around a block of wood or use a store bought holder. Start with a coarse grade of paper and finish with a fine grade paper (not included).
3. Be consistent. Do not sand one area with fine paper and another with coarse grade paper.

#### STAINING

1. Be sure the wood surface is smooth and clean. Stains can accentuate any roughness or scratches of cross grain sanding. Wipe off any dirt or dust with a soft cloth.
2. A base coat of sealer/primer and a light sanding before applying stain will ensure a uniform stain.
3. Apply stains in one direction following the wood grain. Use a soft brush or foam brush. Let the stain penetrate the wood, then wipe off excess stain with a soft cloth.
4. If stain looks too dark, dampen the cloth with water/thinner and wipe until you achieve the desired color. If stain is too light, let dry, then apply another coat of stain and wipe off.

#### FINISHES

1. Outdoor projects may be finished with polyurethane or varnish. **These are toxic and must be used in a well ventilated area.** Indoor projects may be finished with decoupage or left unfinished.

**MAKING IT EASY to SAVE MORE on your next order!**

**15% OFF**  
No \$ Minimum

Please mention Offer Code: **M2467**

Limit one per order.

May not be combined with other offers  
or bid or contract pricing.

See [ssww.com](http://ssww.com) for Offer Terms and Conditions.

We reserve the right to terminate this  
offer at any time without notice.

Call Toll-Free  
**1-800-243-9232**

Online:  
**SSWW.COM**

Email:  
**cservice@ssww.com**

FAX:  
**1-800-566-6678**

**S&S** Worldwide

© Copyright 2018 S&S® Worldwide Inc. All rights reserved.  
No part of this project may be copied or duplicated without the express written permission of S&S Worldwide.

**Kit may contain silicone gel packets, which should be removed before use.**

Reorder Number

GA7519C

1.1

**S&S**® Worldwide  
**MAKING IT EASY**  
to Help People Play and Learn Since 1906

## Classic Cars - Model A

PLEASE READ ALL INSTRUCTIONS BEFORE STARTING

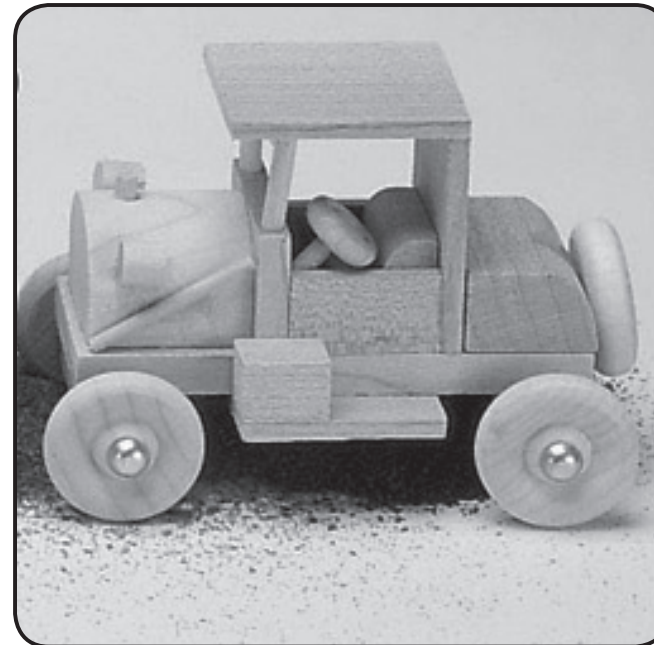

#### YOUR KIT CONTAINS:

- Wood Pieces
- Wood Dowels
- 4 Metal Rivets

#### YOU WILL NEED:

- Wood Glue
- Ruler
- Sandpaper (Optional)
- Acrylic Craft Paint (Optional)
- Stain (Optional)
- Brushes (Optional)
- Flat Work Surface

**PREP TIME: 10 minutes**  
**PROJECT TIME: 30 minutes**

**INSTRUCTIONS:**

1. Before starting, read through instructions, then lay out and identify each piece. All parts are pre-sanded, but finish sanding is suggested. Remove any excess dust with a soft cloth after sanding.
2. Stain or paint the wood parts if desired. A combination of stain and paint looks nice. Let dry 30 minutes (Make sure when gluing to allow pieces to dry between steps).
3. Glue rear axle (1-1/2" x 3/8") approximately 1/4" from rear of chassis (3" x 1-3/16") and glue front axle flush with front of chassis. Glue steps (1-3/16" x 1/2") centered between wheels and flush to outside of wheel. Glue exhaust pipe (3/16" x 1/2" fat dowel) to rear of axle, off centered to the right. Glue trunk flush to rear of chassis. Glue cab wall (1-3/16" x 1-3/8") flush to trunk and flush with top side edges of chassis. Glue doors (3/4" x 1/2") flush to cab wall and chassis (See Figure A).
4. Glue seat to chassis and flush to cab wall, centered left to right (See Figure B).
5. Glue steering post (1/8" x 1/2" long dowel) into steering wheel and glue post into hole in the firewall (1-3/16" x 3/4"). Glue windshield posts (1/8" x 3/4" dowels) into holes in top of the firewall (See Figure C).
6. Glue firewall flush to doors (See Figure D).
7. Glue hood to chassis flush to firewall and centered left to right. Glue the two headlights (1/4" stubby dowels) into the side of hood about 3/8" from bottom of hood and extending about 1/8" beyond front of the hood. Glue gas cap (1/8" x 1/4" dowel) into hole in top of the hood (See Figure E).
8. Glue windshield supports (1/12" x 1" long skinny dowels) one on each side - from top of firewall to chassis (See Figure F).
9. Glue roof flush to back of cab wall and overhanging windshield posts. Glue tool box (1/2" x 3/8") on top of step. Attach wheels by pushing the metal rivets through the wheels and into the holes in the sides of the chassis (See Figure G).
10. Attach spare tire to the trunk and rear of the chassis (See Figure G).

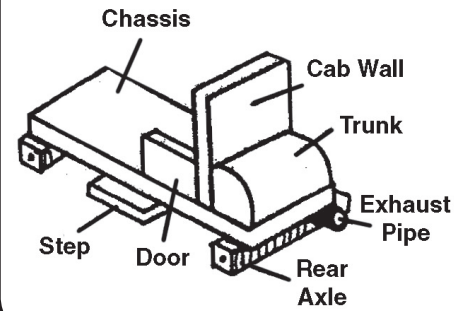
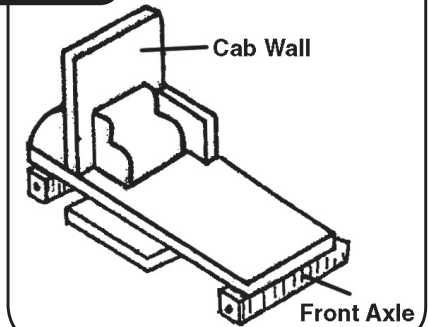
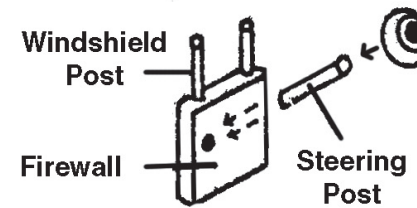
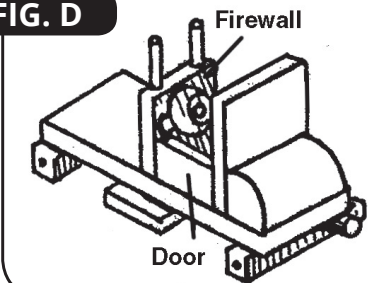
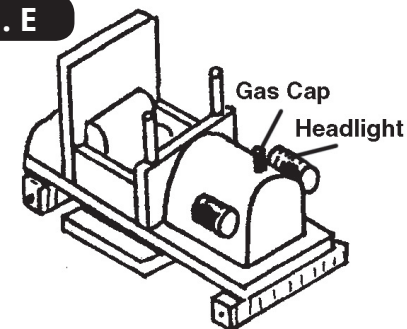
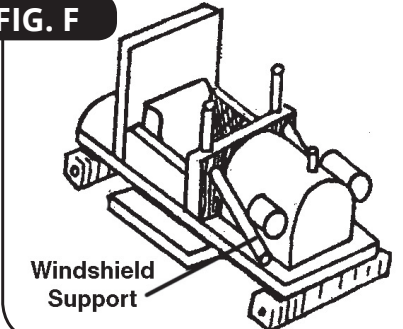
**FIG. A****FIG. B****FIG. C****FIG. D****FIG. E****FIG. F****FIG. G**