

GA7519D

Classic Cars - Model T

GENERAL WOOD INSTRUCTIONS:

SANDING

The rule of sanding is "Never across the grain."

1. Do not tear sandpaper. If you do, the ragged edges will often scratch the wood surface.
2. For flat surfaces, wrap a piece of sandpaper around a block of wood or use a store bought holder. Start with a coarse grade of paper and finish with a fine grade paper (not included).
3. Be consistent. Do not sand one area with fine paper and another with coarse grade paper.

STAINING

1. Be sure the wood surface is smooth and clean. Stains can accentuate any roughness or scratches of cross grain sanding. Wipe off any dirt or dust with a soft cloth.
2. A base coat of sealer/primer and a light sanding before applying stain will ensure a uniform stain.
3. Apply stains in one direction following the wood grain. Use a soft brush or foam brush. Let the stain penetrate the wood, then wipe off excess stain with a soft cloth.
4. If stain looks too dark, dampen the cloth with water/thinner and wipe until you achieve the desired color. If stain is too light, let dry, then apply another coat of stain and wipe off.

FINISHES

1. Outdoor projects may be finished with polyurethane or varnish. **These are toxic and must be used in a well ventilated area.** Indoor projects may be finished with decoupage or left unfinished.

MAKING IT EASY to SAVE MORE on your next order!

15% OFF
No \$ Minimum

Please mention Offer Code: **M2467**

Limit one per order.

May not be combined with other offers
or bid or contract pricing.

See ssww.com for Offer Terms and Conditions.

We reserve the right to terminate this
offer at any time without notice.

Call Toll-Free
1-800-243-9232

Online:
SSWW.COM

Email:
cservice@ssww.com

FAX:
1-800-566-6678

S&S Worldwide

© Copyright 2018 S&S® Worldwide Inc. All rights reserved.
No part of this project may be copied or duplicated without the express written permission of S&S Worldwide.

Kit may contain silicone gel packets, which should be removed before use.

Reorder Number

GA7519D

1.1

S&S® Worldwide
MAKING IT EASY
to Help People Play and Learn Since 1906

Classic Cars - Model T

PLEASE READ ALL INSTRUCTIONS BEFORE STARTING

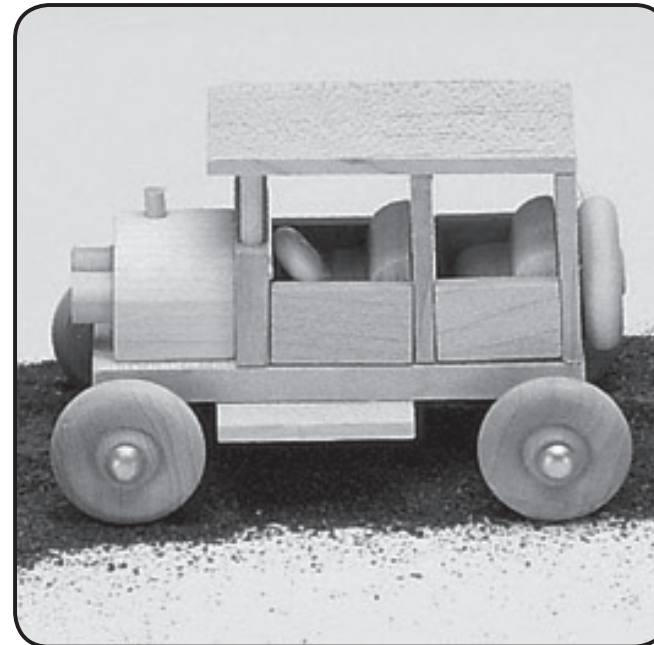

YOUR KIT CONTAINS:

- Wood Pieces
- Wood Dowels
- 4 Metal Rivets

YOU WILL NEED:

- Wood Glue
- Ruler
- Sandpaper (Optional)
- Acrylic Craft Paint (Optional)
- Stain (Optional)
- Brushes (Optional)
- Flat Work Surface

PREP TIME: 10 minutes
PROJECT TIME: 30 minutes

INSTRUCTIONS:

1. Before starting, read through instructions, then lay out and identify each piece. All parts are pre-sanded, but finish sanding is suggested. Remove any excess dust with a soft cloth after sanding.
2. Stain or paint the wood parts if desired. A combination of stain and paint looks nice. Let dry 30 minutes (Make sure when gluing to allow pieces to dry between steps).
3. Glue axles (1-1/2" x 3/8") flush to each end of the chassis and centered left to right. Attach wheels by pushing the metal rivets through the wheels and into the axle holes (See Figure A).
4. Glue steps (1-3/16" x 1/2") to the underside of chassis, centered between the two wheels and flush with the middle of wheel. Glue back wall (1-3/16" x 1-1/4") onto chassis, flush to rear edge of the chassis and also flush with top side edges of the chassis (See Figure B).
5. Glue back seat to chassis and also flush to and centered on the back wall. Glue back (short) doors (3/4" x 1/2") flush to back wall and flush to side of the back seat (See Figure C).
6. As in Step 5, glue center wall flush to back doors and be sure it is the same height as the back wall. Glue front seat flush to center wall and centered left to right. Glue front or long doors (7/8" x 3/4") to the center wall and to the sides of the front seat (See Figure D).
7. Glue steering post (1/8" x 1/2" dowel) into the steering wheel and glue this into hole in the firewall. Glue windshield posts (1/8" x 5/8" dowels) into holes in firewall. Be sure posts are the same height as center and back walls (See Figure E).
8. Glue this firewall assembly flush to the front edge of the front doors (See Figure F).
9. Glue hood to chassis, centered and flush against the front of the firewall. Keep hole in the top of the hood to the front of the car. Glue two headlights (5/16" x 5/16" dowels) on front of hood. Glue radiator cap (1/8" 1/4" dowel) into hold in hood (See Figure G).
10. Glue roof flush to rear of the back wall, overhanging windshield posts in the front. Glue the spare tire onto side of back wall above bottom of rear axle. Glue exhaust pipe (3/16" x 1/2" dowel) to rear axle on the opposite side from spare tire (See Figure H).

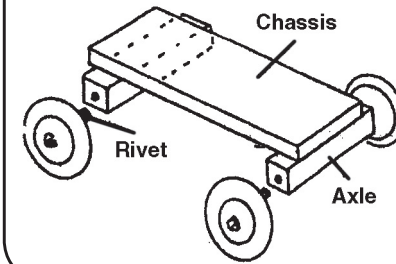
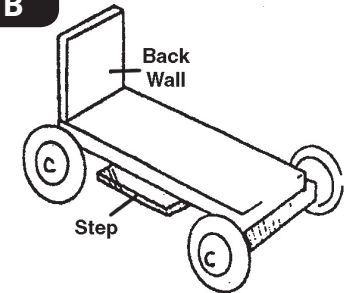
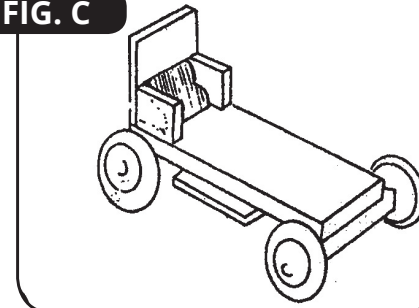
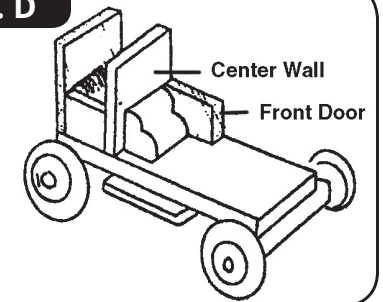
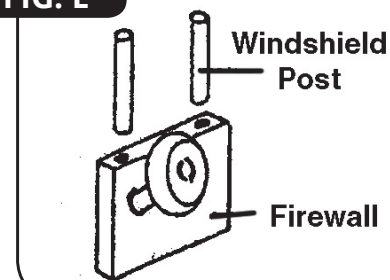
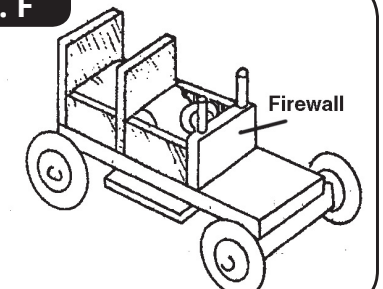
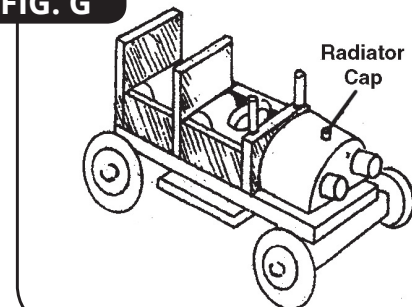
FIG. A**FIG. B****FIG. C****FIG. D****FIG. E****FIG. F****FIG. G****FIG. H**