

General Wood Instructions

Sanding

The rule of sanding is "Never across the grain".

1. Do not tear sandpaper. If you do, the ragged edges will often scratch the wood surface.
2. For flat surfaces, wrap a piece of sandpaper around a block of wood or use a store bought holder. Start with a coarse grade of paper and finish with a fine grade of paper(not included).
3. Be consistent. Do not sand one area with fine and another with coarse grade.

Staining

1. Be sure the wood surface is smooth and clean. Stains can accentuate any roughness or scratches of cross grain sanding. Wipe off any dirt or dust with a soft cloth.
2. A base coat of sealer/primer and a light sanding before applying stain will insure a uniform stain.
3. Apply stains in one direction following the wood grain. Use a soft brush or foam brush. Let the stain penetrate the wood, then wipe off excess stain with a soft cloth.
4. If stain looks too dark, dampen the cloth with water/thinner and wipe until you achieve the desired color. If stain is too light, let dry, then apply another coat of stain and wipe off.

Finishes

1. Outdoor projects may be finished with polyurethane or varnish.

These are toxic and must be used in a well ventilated area. Indoor projects may be finished with decoupage or left unfinished.

Safety First!

This Product May Contain Silicon Gel Packets.
REMOVE PRIOR TO USE!

JEEP WD3206

S&SWorldwide

CALL TOLL-FREE 1-800-243-9232

or **Mail Your Order** to: S&S Worldwide
PO Box 513

Colchester, CT 06415-0513

FAX #: 1-800-566-6678

Customer Service: 1-800-937-3482

Internet home page address: <http://www.ssw.com>

Email address: service@ssww.com

Item No. WD3206

Made in China

JEEP

PLEASE READ ALL INSTRUCTIONS BEFORE STARTING



- Wood Pieces
- Dowels
- Instructions
- Sand Paper



YOU WILL NEED...



Wood Glue

Protected Work Surface

Paint or Stain

Brushes

S&SWorldwide



Prep Instructions:

- ▶ Chell all parts of proper placement. For best results, sand and paint before assembly, avoiding areas to be glued. Glue where you see this symbol:

Product Instructions:

- ▶ Glue 2 short dowels and 2 pieces A to roof B as shown. Allow to dry.
- ▶ Glue bumper C to body D.
- ▶ Glue roof assembly to body.

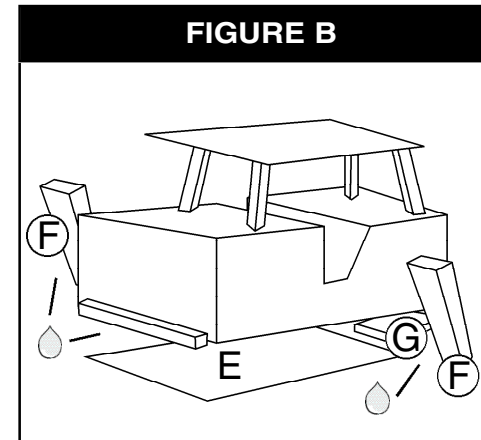
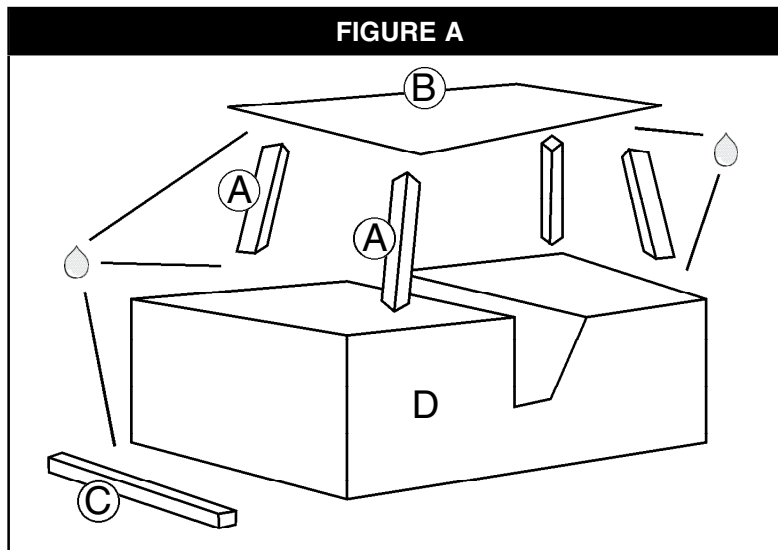

- ▶ Glue base E to bottom of body leaving enough space to fit wheels.
- ▶ Glue fenders F to body.
- ▶ Glue trailer hitch G to bottom rear of body.

- ▶ Glue 2 wheels to each axle.
- ▶ Position each axle into groves of 2 blocks H which you will glue to bottom of body as shown.
- ▶ Glue headlights in place.

